

4023 TR

**Unmatched Power.
Unmatched Performance.**

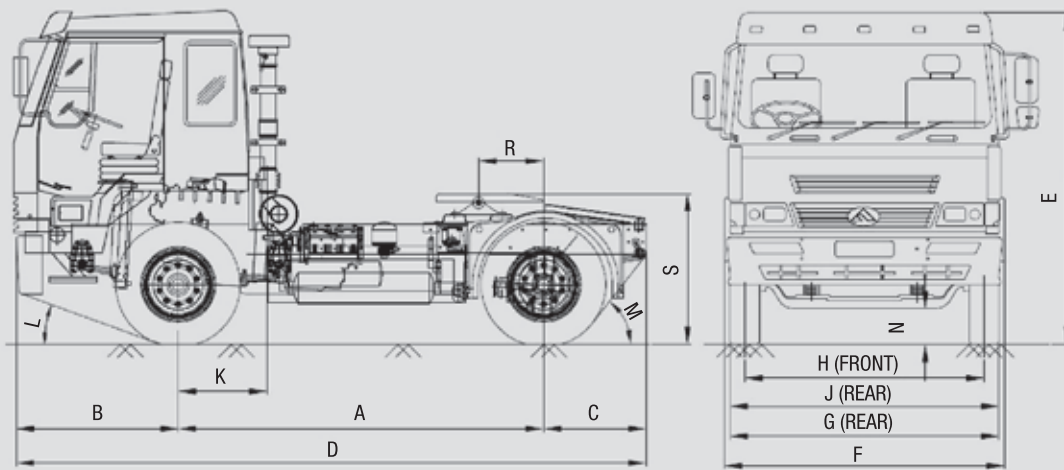



Asia MotorWorks Ltd.

4023 - 3100 WB 4 x 2 TRACTOR

CHASSIS NOMINAL DIMENSIONS - Unladen (mm)

A) Wheel Base	:	3100
B) Front Overhang	:	1350
C) Rear Overhang	:	870
D) Overall Length	:	5325
E) Overall Height (Cab)	:	2700
F) Overall Width (Cab)	:	2475
G) Overall Width (Rear Tyres)	:	2494
H) Wheel Track - Front	:	2020
J) Wheel Track - Rear	:	1856
K) Front Axle to Back of Cabin	:	760
L) Approach Angle	:	20°
M) Departure Angle	:	54°
N) Min Ground Clearance - Front	:	280
Min Ground Clearance - Rear	:	270
Frame Width	:	864
King Pin Size	:	2"
R) King Pin Offset	:	550
S) Height of Fifth Wheel Coupling from Ground	:	1340

WEIGHT (kgs)

	Unladen	Laden (CMVR)
Front Axle	: 3375	6000
Rear Axle	: 2330	10200
Total	: 5705	40200*

*When coupled with the suitable tandem Axle Semi-Trailer

ENGINE

Model: Cummins - 6BTA - BS II
 Type: DI - Turbo Charged after Cooled Diesel Engine
 No. of Cylinders: 6 Inline
 Bore x Stroke: 102 x 120 mm
 Capacity: 5883 cc
 Max Power: 173 kW (232 bhp) @ 2500 rpm
 Max Torque: 800 Nm @ 1500 rpm
 Compression Ratio: 17.3:1
 Oil Sump Capacity: 14.3 ltrs
 Air Filter: Dry Type Remote Mounted
 Oil Filter: Full Flow Paper Type
 Fuel Filter: Single Filter with Water Separator
 Fuel Injection Pump: Inline Type
 Fuel Tank: 220 ltrs

CLUTCH

Valeo, Single Dry Plate Diaphragm Type,
 Hydro-Pneumatically Operated

GEARBOX

Model: 9S, 75 ZF Gearbox - Synchromesh
 Speed Ratios: Crawler 13.16
 I - 8.91, II - 6.50, III - 4.67, IV - 3.50, V - 2.55,
 VI - 1.86, VII - 1.33, VIII - 1.00, Reverse - 11.74

PROPELLER SHAFT

1810 Series: GB to Rear Axle

REAR AXLE

Fully Floating Single Speed Hypoid Gear
 Ratio: 6.17

FRONT AXLE

Forged "I" Beam - Reverse Elliot Type

FRAME

HSLA Steel, Ladder Type Bolted Cross Members
 Side Member: 270 x 82 x 7 mm Channel Reinforced
 with Inner Channel Section of 7 mm Thick

SUSPENSION

Front: Semi-Elliptical Leaf Springs with
 Shock Absorbers
 Span: 1650 mm
 Rear: Semi-Elliptical Leaf Springs with Helper Spring
 Span: 1600 mm

SHOCK ABSORBERS

Heavy Duty, Double-Acting Hydraulic Shock
 Absorbers on Front Suspension

STEERING

Integral Power Steering, with Double UJ. Adjustable
 Steering Wheel - Ratio: 20.4
 Steering Wheel Dia: 475 mm

WHEELS & TYRES

Rims: B7.5 x 20 - 10 Bolts, Spigotted
 Tyres: Front: 11.00 x 20 - 16 PR - 2 Nos. (Highway)
 Rear: 11.00 x 20 - 16 PR - 4 Nos. (Lug)
 Spare: 11.00 x 20 - 16 PR - 1 No. (Highway)

BRAKES

Service Brake: Dual Circuit Full Air
 Parking Brake: Spring Actuated on Rear Axles
 Engine Exhaust Brake: Butterfly Type, Provided

ELECTRICAL SYSTEM

System: 24 Volts (Negative Earth)
 Alternator: 45 A (75 A for A/C: Optional)
 Battery: 2 x 12v x 88 Amp hr (20 hr rating) - Non A/C
 Battery: 2 x 12v x 120 Amp hr (20 hr rating)
 - A/C (Optional)

CABIN

Fully Furnished, Tiltable Sleeper Cabin
 A/C (Optional)

FIFTH WHEEL COUPLER

Pressed Steel Construction with Automatic
 Wear Adjuster
 King Pin Size: 2" Dia

PERFORMANCE (@ 40,200 kgs)

Max Speed-Geared (kmph): 80.0
 Max Gradeability (%): Running
 First Gear: 18.0
 Min Turning Circle Radius-mm: 11250
 (With Trailer Coupled)

Technical specifications are subject to change without notice.
 Accessories shown are not part of the standard fitment.

